



SUSSMAN

ELECTRIC BOILERS

HU Series

Lbs/Hr Sat. Steam: 36 to 542

KW Rating: 12 to 180

ASME Rating 15 PSIG

Operating PSIG Range 0-12 PSIG Max

HU Electric Steam Humidification Generator

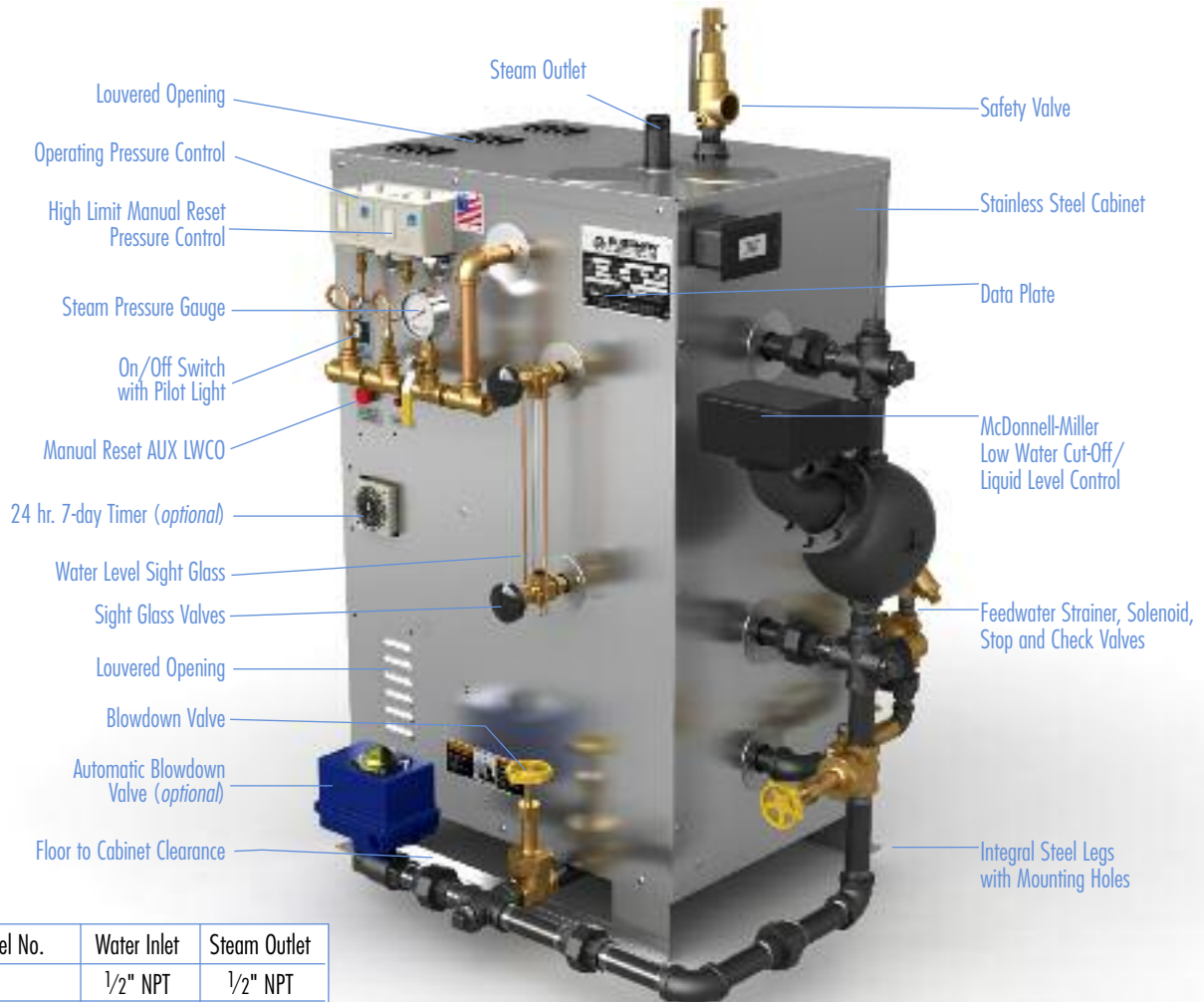

Boiler Model No.	Water Inlet	Steam Outlet
HU 40-50	1/2" NPT	1/2" NPT
HU 75-205	1/2" NPT	1" NPT
HU 250-310	1/2" NPT	3" NPT
HU410 thru HU 550	1/2" NPT	3" NPT

Built to ASME Code



Typical boiler arrangement

HU Electric Steam Humidification Generators

The Sussman HU Series Steam humidification line of generators has been designed to provide atmospheric, low pressure (under 15 PSIG) steam for a multitude of humidification and HVAC requirements. High quality steam is efficiently and quietly generated with minimal generator heat loss to the surroundings.

The Sussman HU Series is designed to operate in conjunction with any commercial steam humidifier equipment including duct-work installed humidifiers. Instantaneous and reserve-capacity steam is manufactured within the pressure vessel for continuous and intermittent steam flow rate requirements. Vessel design minimizes carry-over and heating elements are designed for maximum element-to-water contact for efficient operation.

Suitable for almost any application or environment requiring a steam source for humidification purposes, the Sussman HU Series Generators are recommended for:

- Protection of humidity-sensitive materials, machinery equipment
- Reduction of static electricity in computer rooms and professional offices.
- In the workplace, warehouse, copying/reproduction rooms and wherever furniture, paper or food goods are used or stored.
- Assuring a comfort-zone for personnel working in hospitals, offices, libraries, schools, factory staging and packing areas.

HU-Standard Features

- **WATER FEED SYSTEM** - Strainer, solenoid valve, stop valve and check valve factory wired and plumbed for direct connection to water line.
- **LOW WATER CUT-OFF/LEVEL CONTROL** - McDonnell Miller No.150 control automatically maintains proper water level, shutting off the boiler when water supply drops below a safe operating level.
- **WATER LEVEL SIGHT GLASS** - Allows constant observation of water level while boiler is in operation.
- **MAIN ON/OFF SWITCH** - Allows manual operation of the boiler operating control circuit.
- **PILOT LIGHT** - Indicates control circuit's ON/OFF condition.
- **INTEGRAL POWER CONTACTORS** - Magnetic contactors for energizing the boiler elements. Integrally mounted in the control unit.
- **BLOWDOWN/DRAIN VALVES** - Facilitates emptying the pressure vessel and MM150 and water column piping during blowdown sequence.
- **LONG LIFE HEATING ELEMENTS** - Industrial grade, heavy duty 0.420 inch diameter stainless steel heating elements, equipped with one piece resistance welded terminations for added strength and safety.
- **OPERATING PRESSURE CONTROL** - Resets automatically to maintain preset pressure within the boiler.
- **ENERGY SAVINGS AND MINIMUM MAINTENANCE** - Pressure vessel insulation minimizes heat loss and maximizes energy savings, insured by fibrous glass material.
- **EASY CONTROL MAINTENANCE** - All control panels and components are easily accessible. Fully-louvered openings avoid component heat build-up.
- **NEMA 1 Louvered enclosure standard**
- **TRIM PRESSURE** - Factory standard 15 PSIG

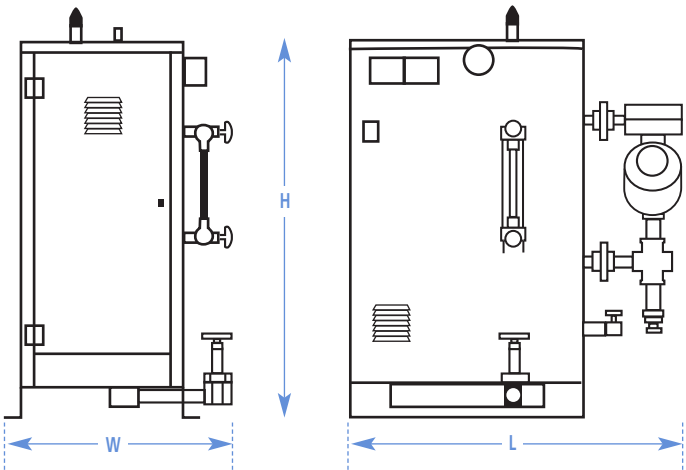

Specifications for HU Boilers

Boiler Model	kW*	BHP Rating	Lbs./Hr. Steam**	3 Phase Voltage†	Amps	Dimensions (in)			Shipping Wt.
						W	L††	H	
HU-40	12	1.22	36.2	208 240 480	34 29 15	20	28	36	200
HU-55	18	1.84	54.2	208 240 480	50 44 22	20	28	36	200
HU-75	24	2.45	72.3	208 240 480	67 58 29	23	33	44	330
HU-90	30	3.06	90.4	208 240 480	84 73 37	23	33	44	330
HU-105	36	3.67	108	208 240 480	100 87 44	23	33	44	330
HU-140	48	4.90	145	208 240 480	134 116 59	23	33	44	330
HU-175	60	6.12	181	208 240 480	167 145 73	23	33	44	330
HU-205	72	7.35	217	208 240 480	200 174 87	23	33	44	330
HU-250	85	8.5	256	208 240 480	236 204 102	28	34	59	680
HU-310	108	11.0	325	208 240 480	300 260 130	28	34	59	680
HU-410	144	14.6	433	208 240 480	400 347 173	30	36	59	680
HU-475	158	16.1	475	240 480	379 190	30	36	61	680
HU-550	180	18.4	542	240 480	434 217	30	36	61	680

Notes: * Single phase available
 **Lbs/hr steam at 212° F with 50°F feedwater
 † Other voltages available
 ††Allow 21 inches for heating element removal

Meeting Code Requirements

- Pressure vessel rated at 100 PSIG to ASME Section 1.
- Vessel National Board Registered
- UL and cUL Listed
- Electrical construction conforms to NEC standards.

Safety Features

- **STEAM SAFETY VALVE** - ASME Code valve, automatically opens to reduce pressure should excessive steam cause pressure build-up.
- **STEAM PRESSURE GAUGE** - Allows visual observation of steam pressure over full range.
- **MANUAL RESET PRESSURE CONTROL** - Provides high limit pressure cut-out with manual reset.
- **AUXILIARY LWCO with Manual Reset** - Standard electronic back-up to primary MM150 control.

Standard Optional Equipment

- **AUTOFLUSH AND DRAIN** - For automatic daily flush/blowdown of pressure vessel and piping; motorized valve with steam rated seat, valving with 24 hour programmable timer.